

Improved Active Power Filter Performance for Renewable Power Generation Systems Using FLC

B.Prashanth Goud

**Pursuing M.Tech, PE Branch,
Dept of EEE,**

Brilliant Institute of Engineering and Technology.

P.Dileep Kumar

**Associate Professor,
Dept of EEE,**

Brilliant Institute of Engineering and Technology.

Abstract:

Renewable generation affects power quality (PQ), since solar generation and wind power generators are intermittent renewable energy source (RES). The non-linear nature of loads can cause load current harmonics, unbalanced currents and can create PQ problem. This paper presents the four leg voltage source inverter as a grid interfacing inverter in 3-phase 4-wire distribution systems with linear/nonlinear unbalanced load, which can improve the PQ performance. The four leg voltage source inverter can be used to inject power generated from RES to grid, and as shunt APF to compensate current unbalance, load current harmonics, load reactive power demand and load neutral current.

Index Terms:

Renewable energy source (RES), distributed generation (DG), four leg converter, active power filter (APF), power quality (PQ).

I. INTRODUCTION:

Electric utilities and end users of electric power are becoming increasingly concerned about meeting the growing energy demand. Seventy five percent of total global energy demand is supplied by the burning of fossil fuels. But increasing air pollution, global warming concerns, diminishing fossil fuels and their increasing cost have made it necessary to look towards renewable sources as a future energy solution. Since the past decade, there has been an enormous interest in many countries on renewable energy for power generation. The market liberalization and government's incentives have further accelerated the renewable energy sector growth.

Renewable energy source (RES) integrated at distribution level is termed as distributed generation (DG). The utility is concerned due to the high penetration level of intermittent RES in distribution systems as it may pose a threat to network in terms of stability, voltage regulation and power-quality (PQ) issues. Therefore, the DG systems are required to comply with strict technical and regulatory frameworks to ensure safe, reliable and efficient operation of overall network. With the advancement in power electronics and digital control technology, the DG systems can now be actively controlled to enhance the system operation with improved PQ at PCC. However, the extensive use of power electronics based equipment and non-linear loads at PCC generate harmonic currents, which may deteriorate the quality of power [1], [2].

Generally, current controlled voltage source inverters are used to interface the intermittent RES in distributed system. Recently, a few control strategies for grid connected inverters incorporating PQ solution have been proposed. In [3] an inverter operates as active inductor at a certain frequency to absorb the harmonic current. But the exact calculation of network inductance in real-time is difficult and may deteriorate the control performance. A similar approach in which a shunt active filter acts as active conductance to damp out the harmonics in distribution network is proposed in [4]. In [5], a control strategy for renewable interfacing inverter based on p-q- theory is proposed. In this strategy both load and inverter current sensing is required to compensate the load current harmonics. The non-linear load current harmonics may result in voltage harmonics and can create a serious PQ problem in the power system network.

Active power filters (APF) are extensively used to compensate the load current harmonics and load unbalance at distribution level. This results in an additional hardware cost. However, in this paper authors have incorporated the features of APF in the, conventional inverter interfacing renewable with the grid, without any additional hardware cost. Here, the main idea is the maximum utilization of inverter rating which is most of the time underutilized due to intermittent nature of RES. It is shown in this paper that the grid-interfacing inverter can effectively be utilized to perform following important functions: 1) transfer of active power harvested from the renewable resources (wind, solar, etc.); 2) load reactive power demand support; 3) current harmonics compensation at PCC; and 4) current unbalance and neutral current compensation in case of 3-phase 4-wire system.

Moreover, with adequate control of grid-interfacing inverter, all the four objectives can be accomplished either individually or simultaneously. The PQ constraints at the PCC can therefore be strictly maintained within the utility standards without additional hardware cost. The paper is arranged as follows: Section II describes the system under consideration and the controller for grid-interfacing inverter. A digital simulation study is presented in Section III. Extensive experimental results are discussed in Section IV and, finally, Section V concludes the paper.

II. SYSTEM DESCRIPTION:

The proposed system consists of RES connected to the dc-link of a grid-interfacing inverter as shown in Fig. 1. The voltage source inverter is a key element of a DG system as it interfaces the renewable energy source to the grid and delivers the generated power. The RES may be a DC source or an AC source with rectifier coupled to dc-link. Usually, the fuel cell and photovoltaic energy sources generate power at variable low dc voltage, while the variable speed wind turbines generate power at variable ac voltage. Thus, the power generated from these renewable sources needs power conditioning (i.e., dc/dc or ac/dc) before connecting on

dc-link [6]–[8]. The dc-capacitor decouples the RES from grid and also allows independent control of converters on either side of dc-link.

A. DC-Link Voltage and Power Control Operation

Due to the intermittent nature of RES, the generated power is of variable nature. The dc-link plays an important role in transferring this variable power from renewable energy source to the grid. RES are represented as current sources connected to the dc-link of a grid-interfacing inverter. Fig. 2 shows the systematic representation of power transfer from the renewable energy resources to the grid via the dc-link. The current injected by renewable into dc-link at voltage level V_{dc} can be given as

$$I_{dc1} = \frac{P_{RES}}{V_{dc}} \tag{1}$$

Where P_{RES} is the power generated from RES.

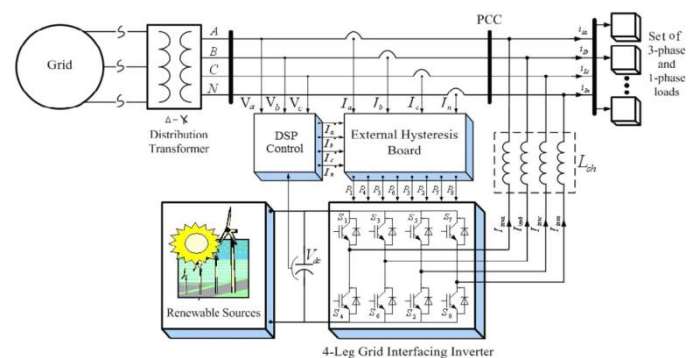

Fig.1. Schematic of proposed renewable based distributed generation system

The current flow on the other side of dc-link can be represented as,

$$I_{dc2} = \frac{P_{inv}}{V_{dc}} = \frac{P_G + P_{Loss}}{V_{dc}} \tag{2}$$

Where P_{inv} , P_G and P_{Loss} are total power available at grid-interfacing inverter side, active power supplied to the grid and inverter losses, respectively. If inverter losses are negligible then $P_{RES} = P_G$.

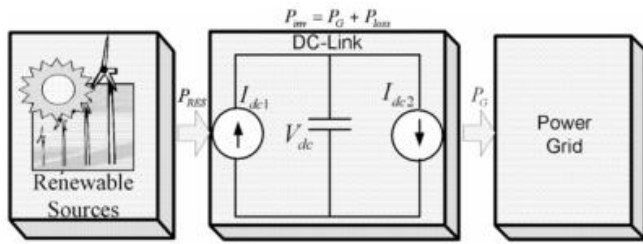

Fig 2. DC link equivalent diagram

B. Control of Grid Interfacing Inverter:

The control diagram of grid- interfacing inverter for a 3-phase 4-wire system is shown in Fig. 3. The fourth leg of inverter is used to compensate the neutral current of load. The main aim of proposed approach is to regulate the power at PCC during: 1) $P_{RES}=0$; 2) $P_{RES} =$ total load power (P_L); and 3) $P_{RES} >P_L$. While performing the power management operation, the inverter is actively controlled in such a way that it always draws/ supplies fundamental active power from/ to the grid. If the load connected to the PCC is non-linear or unbalanced or the combination of both, the given control approach also compensates the harmonics, unbalance, and neutral current.

The duty ratios of inverter switches are varied in a power cycle such that the combination of load and inverter injected power appears as balanced resistive load to the grid. The regulation of dc-link voltage carries the information regarding the exchange of active power in between renewable source and grid. Thus the output of dc-link voltage regulator results in an active current (I_m).

The multiplication of active current component (I_m) with unity grid voltage vector templates (U_a, U_b and U_c) generates the reference grid currents (I_a^*, I_b^*, I_c^*). The reference grid neutral current (I_n^*) is set to zero, being the instantaneous sum of balanced grid currents. The grid synchronizing angle (θ) obtained from phase locked loop (PLL) is used to generate unity vector template as [9]–[11]

$$U_a = \sin(\theta) \tag{3}$$

$$U_b = \sin(\theta - \frac{2\pi}{3}) \tag{4}$$

$$U_c = \sin(\theta + \frac{2\pi}{3}). \tag{5}$$

The actual dc-link voltage (V_{dc}) is sensed and passed through a first-order low pass filter (LPF) to eliminate the presence of switching ripples on the dc-link voltage and in the generated reference current signals. The difference of this filtered dc-link voltage and reference dc-link voltage (V_{dc}^*) is given to a discrete-PI regulator to maintain a constant dc-link voltage under varying generation and load conditions. The dc-link voltage error $V_{dcerr}(n)$ at n th sampling instant is given as:

$$V_{dcerr}(n) = V_{dc}^*(n) - V_{dc}(n). \tag{6}$$

The output of discrete-PI regulator at n th sampling instant is expressed as

$$I_m(n) = I_m(n-1) + K_{PVdc}(V_{dcerr}(n) - V_{dcerr}(n-1)) + K_{IVdc}V_{dcerr}(n) \tag{7}$$

Where $K_{PVdc}=10$ and $K_{IVdc}=0.05$ are proportional and integral gains of dc-voltage regulator. The instantaneous values of reference three phase grid currents are computed as

$$I_a^* = I_m \cdot U_a \tag{8}$$

$$I_b^* = I_m \cdot U_b \tag{9}$$

$$I_c^* = I_m \cdot U_c. \tag{10}$$

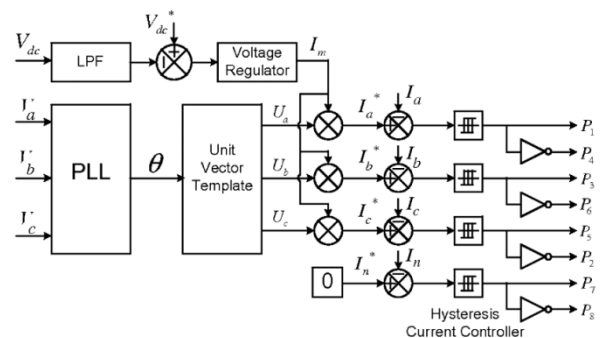

Fig3. Block diagram representation of grid interfacing inverter control

The neutral current, present if any, due to the loads connected to the neutral conductor should be compensated by forth leg of grid-interfacing inverter and thus should not be drawn from the grid. In other words, the reference current for the grid neutral current is considered as zero and can be expressed as

$$I_n^* = 0. \tag{11}$$

The reference grid currents (I_a^* , I_b^* , I_c^* and I_n^*) are compared with actual grid currents (I_a , I_b , I_c and I_n) to compute the current errors as

$$I_{aerr} = I_a^* - I_a \tag{12}$$

$$I_{berr} = I_b^* - I_b \tag{13}$$

$$I_{cerr} = I_c^* - I_c \tag{14}$$

$$I_{nerr} = I_n^* - I_n \tag{15}$$

These current errors are given to hysteresis current controller. The hysteresis controller then generates the switching pulses (P_1 to P_8) for the gate drives of grid-interfacing inverter. The average model of 4-leg inverter can be obtained by the following state space equations.

$$\frac{dI_{Inva}}{dt} = \frac{(V_{Inva} - V_a)}{L_{sh}} \tag{16}$$

$$\frac{dI_{Invb}}{dt} = \frac{(V_{Invb} - V_b)}{L_{sh}} \tag{17}$$

$$\frac{dI_{Invc}}{dt} = \frac{(V_{Invc} - V_c)}{L_{sh}} \tag{18}$$

$$\frac{dI_{Invn}}{dt} = \frac{(V_{Invn} - V_n)}{L_{sh}} \tag{19}$$

$$\frac{dV_{dc}}{dt} = \frac{(I_{Invad} + I_{Invbd} + I_{Invcd} + I_{Invnd})}{C_{dc}} \tag{20}$$

Where V_{Invad} , V_{Invbd} , V_{Invcd} , and V_{Invnd} are the three-phase ac Switching voltages generated on the output terminal of inverter. These inverter output voltages can be modeled in terms of instantaneous dc bus voltage and switching pulses of the inverter as

$$V_{Inva} = \frac{(P_1 - P_4)}{2} V_{dc} \tag{21}$$

$$V_{Invb} = \frac{(P_3 - P_6)}{2} V_{dc} \tag{22}$$

$$V_{Invc} = \frac{(P_5 - P_2)}{2} V_{dc} \tag{23}$$

$$V_{Invn} = \frac{(P_7 - P_8)}{2} V_{dc} \tag{24}$$

Similarly the charging currents I_{Invad} , I_{Invbd} , I_{Invcd} , and I_{Invnd} on dc bus due to the each leg of inverter can be expressed as

$$I_{Invad} = I_{Inva}(P_1 - P_4) \tag{25}$$

$$I_{Invbd} = I_{Invb}(P_3 - P_6) \tag{26}$$

$$I_{Invcd} = I_{Invc}(P_5 - P_2) \tag{27}$$

$$I_{Invnd} = I_{Invn}(P_7 - P_8) \tag{28}$$

The switching pattern of each IGBT inside inverter can be formulated on the basis of error between actual and reference current of inverter, which can be explained as: If $I_{Inva} < (I_{Inva}^* - h_b)$, then upper switch will be OFF and ($P_1=0$) lower switch will be ON ($P_4=1$) in the phase “a” leg of inverter. If $I_{Inva} > (I_{Inva}^* + h_b)$, then upper switch will be ON ($P_1=1$) and lower switch will be OFF ($P_4=0$) in the phase “a” leg of inverter. Where h_b is the width of hysteresis band. On the same principle, the switching pulses for the other remaining three legs can be derived.

III. SIMULATION RESULTS:

In order to verify the proposed control approach to achieve Multi- objectives for grid interfaced DG systems connected to a 3-phase 4-wire network; an extensive simulation study is carried out using MATLAB/ Simulink. A 4-leg current controlled voltage source inverter is actively controlled to achieve balanced sinusoidal grid currents at unity power factor (UPF) despite of highly unbalanced nonlinear load at PCC under varying renewable generating conditions. A RES with variable output power is connected on the dc-link of grid-interfacing inverter.

An unbalanced 3-phase 4-wire non linear load, whose unbalance, harmonics, and reactive power need to be compensated, is connected on PCC. The waveforms of grid voltage (V_a , V_b and V_c), grid currents (I_a , I_b , I_c and I_n), unbalanced load current (I_{1a} , I_{1b} , I_{1c} and I_{1n}) and inverter currents (I_{Inva} , I_{Invb} , I_{Invc} and I_{Invn}) are shown in Fig. 4. The corresponding active-reactive powers of grid (P_{grid} , Q_{grid}), load (P_{load} , Q_{load}) and inverter are shown in Fig. 5. Positive values of grid active-reactive powers and inverter active-reactive powers imply that these powers flow from grid side towards PCC and from inverter towards PCC, respectively. The active and reactive powers absorbed by the load are denoted by positive signs. Initially, the grid-interfacing inverter is not connected to the Network (i.e., the load power demand is totally supplied by the grid alone). Therefore, before time $t=0.72s$, the grid current profile in Fig. 4(b) is identical to the load current profile Fig. 4 (c). At $t=0.72s$, the grid-interfacing inverter is connected to the network. At this instant the inverter starts injecting the current in such a way that the profile of grid current starts changing from unbalanced non linear to balanced sinusoidal current as shown in Fig. 4(b).

As the inverter also supplies the load neutral current demand, the grid neutral current becomes zero after $t=0.72s$. At $t=0.72s$, the inverter starts injecting active power generated from RES ($P_{RES} \approx P_{INV}$). Since the generated power more than the load power demand the additional power is feedback to the grid. The negative sign of P_{grid} , after time 0.72s suggests that the grid is now receiving power from RES. Moreover, the grid-interfacing inverter also supplies the load reactive power demand locally. Thus, once the inverter is in operation the grid only supplies/receives fundamental active power. At $t=0.82s$, the active power from RES is increased to evaluate the performance of system under variable power generation from RES. This results in increased magnitude of inverter current. As the load power demand is considered as constant, this additional power generated from RES flows towards grid, which can be noticed from the increased magnitude of grid current as indicated by its profile.

At $t=0.92s$, the power available from RES is reduced. The corresponding change in the inverter and grid currents can be seen from Fig. 4. The active and reactive power flows between the inverter, load and grid during increase and decrease of energy generation from RES can be noticed from Fig. 5. The dc-link voltage across the grid- interfacing inverter (Fig. 5(d)) during different operating condition is maintained at constant level in order to facilitate the active and reactive power flow. Thus from the simulation results, it is evident that the grid- interfacing inverter can be effectively used to compensate the load reactive power, current unbalance and current harmonics in addition to active power injection from RES. This enables the grid to supply/ receive sinusoidal and balanced power at UPF.

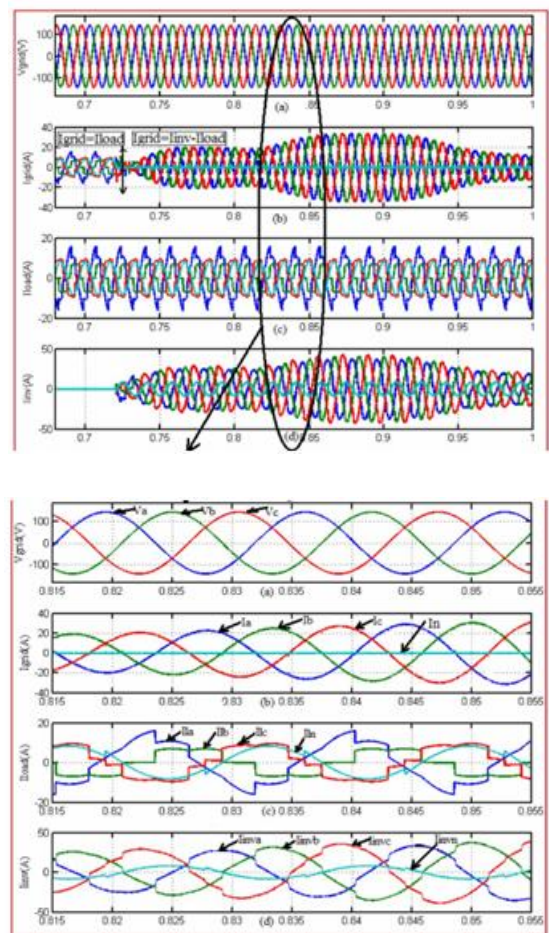

Fig 4. simulation results (a) grid voltages, (b) grid currents, (c) unbalanced load currents and (d) inverter currents.

IV. CONCLUSION:

This paper has presented a four leg voltage source inverter at PCC for a 3-phase 4-wire DG system. It has been shown that the grid-interfacing inverter can be effectively utilized for power conditioning without affecting its normal operation of real power transfer. The grid-interfacing inverter with the proposed approach can be utilized to: i) inject real power generated from RES to the grid, and/or, ii) Operate as a shunt Active Power Filter (APF). This approach thus eliminates the need for additional power conditioning equipment to improve the quality of power at PCC. Extensive MATLAB/Simulink simulation results have validated the proposed approach and have shown that the grid-interfacing inverter can be utilized as a multi-function.

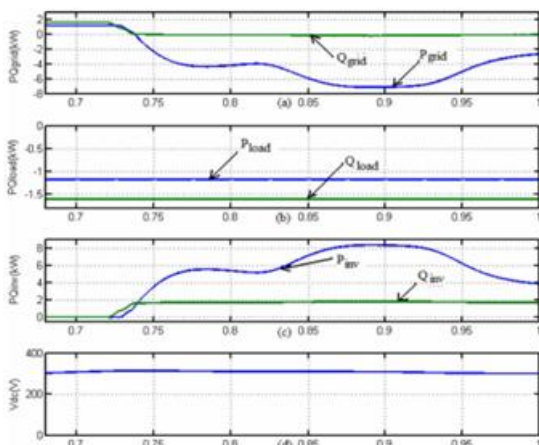

Fig 5. Simulation results (a) P-Q grid, (b) P-Q load, (c) PQ inverter, (d) dc link voltage

Device. It is further demonstrated that the PQ enhancement can be achieved under three different scenarios: 1) $P_{RES} = 0$, 2) $P_{RES} < P_{LOAD}$, and 3) $P_{RES} > P_{LOAD}$. The current unbalance, current harmonics and load reactive power, due to unbalanced and non-linear load connected to the PCC, are compensated effectively such that the grid side currents are always maintained as balanced and sinusoidal at unity power factor. Moreover, the load neutral current is prevented from flowing into the grid side by compensating it locally from the fourth leg of inverter. When the power generated from RES is more than the total load power demand, the grid-interfacing inverter with the

proposed control approach not only fulfills the total load active and reactive power demand (with harmonic compensation) but also delivers the excess generated sinusoidal active power to the grid at unity power factor.

REFERENCES:

- [1] J. M. Guerrero, L. G. de Vicuna, J. Matas, M. Castilla, and J. Miret, "A wireless controller to enhance dynamic performance of parallel inverters in distributed generation systems," *IEEE Trans. Power Electron.*, vol. 19, no. 5, pp. 1205–1213, Sep. 2004.
- [2] J. H. R. Enslin and P. J. M. Heskes, "Harmonic interaction between a large number of distributed power inverters and the distribution network," *IEEE Trans. Power Electron.*, vol. 19, no. 6, pp. 1586–1593, Nov. 2004.
- [3] U. Borup, F. Blaabjerg, and P. N. Enjeti, "Sharing of nonlinear load in parallel-connected three-phase converters," *IEEE Trans. Ind. Appl.*, vol. 37, no. 6, pp. 1817–1823, Nov./Dec. 2001.
- [4] P. Jintakosonwit, H. Fujita, H. Akagi, and S. Ogasawara, "Implementation and performance of cooperative control of shunt active filters for harmonic damping throughout a power distribution system," *IEEE Trans. Ind. Appl.*, vol. 39, no. 2, pp. 556–564, Mar./Apr. 2003.
- [5] J. P. Pinto, R. Pregitzer, L. F. C. Monteiro, and J. L. Afonso, "3-phase 4-wire shunt active power filter with renewable energy interface," presented at the Conf. IEEE Renewable Energy & Power Quality, Seville, Spain, 2007.
- [6] F. Blaabjerg, R. Teodorescu, M. Liserre, and A. V. Timbus, "Overview of control and grid synchronization for distributed power generation systems," *IEEE Trans. Ind. Electron.*, vol. 53, no. 5, pp. 1398–1409, Oct. 2006.

- [7] J. M. Carrasco, L. G. Franquelo, J. T. Bialasiewicz, E. Galván, R. C.P. Guisado, M. Á. M. Prats, J. I. León, and N. M. Alfonso, "Power electronic systems for the grid integration of renewable energy sources: A survey," *IEEE Trans. Ind. Electron.*, vol. 53, no. 4, pp. 1002–1016, Aug. 2006.
- [8] B. Renders, K. De Gussemé, W. R. Ryckaert, K. Stockman, L. Vandeveldé, and M. H. J. Bollen, "Distributed generation for mitigating voltage dips in low-voltage distribution grids," *IEEE Trans. Power Del.*, vol. 23, no. 3, pp. 1581–1588, Jul. 2008.
- [9] V. Khadkikar, A. Chandra, A. O. Barry, and T. D. Nguyen, "Application of UPQC to protect a sensitive load on a polluted distribution network," in *Proc. Annu. Conf. IEEE Power Eng. Soc. Gen. Meeting*, 2006, pp. 867–872.
- [10] M. Singh and A. Chandra, "Power maximization and voltage sag/swell ride-through capability of PMSG based variable speed wind energy conversion system," in *Proc. IEEE 34th Annu. Conf. Indus. Electron. Soc.*, 2008, pp. 2206–2211.
- [11] P. Rodríguez, J. Pou, J. Bergas, J. I. Candela, R. P. Burgos, and D. Boroyevich, "Decoupled double synchronous reference frame PLL for power converters control," *IEEE Trans. Power Electron.*, vol. 22, no. 2, pp. 584–592, Mar. 2007.