

Energy Management of Micro grid Inverter with Coordination Control

K.Gracemary

Pursuing M.Tech, PE Branch, Department of EEE.

ABSTRACT

This paper provides a comprehensive solution for the operation of a micro grid which will simultaneously dispatch real and reactive power during both grid-connected and islanded operations. In this paper an energy-management algorithm is designed for the micro grid to coordinate the sharing of power among different DG units. The proposed micro grid consists of a photovoltaic (PV) array which functions as the primary generation unit of the micro grid and a proton-exchange membrane fuel cell to supplement the variability in the power generated by the PV array. The storage battery (SB) is implemented for peak shaving during grid-connected operation, and to supply power for any shortage in generated power during islanded operation and to maintain the stability of the distribution network. The control design for the DG inverters employs a new model predictive control algorithm which enables faster computational time for large power systems by optimizing the steady-state and the transient control problems separately. The design concept is verified through various test scenarios to demonstrate the operational capability of the proposed micro grid, and the obtained results are discussed.

I.INTRODUCTION

The application of distributed power generation has been increasing rapidly in the past decades. Compared to the conventional centralized power generation, distributed generation (DG) units deliver clean and renewable power close to the customer's end [1]. Therefore, it can alleviate the stress of many conventional transmission and distribution infrastructures. As most of the DG units are interfaced to the grid using power electronics converters, they have the opportunity to realize enhanced power generation through a flexible digital control of the power converters. The current research is also focused on achieving a smarter grid through demand-side

management (DSM), increasing energy reserves and improving the power quality of the distribution system, such as harmonic compensation for nonlinear loads [5]–[8]. The integration of renewable sources can supplement the generation from the distribution grid. However, these renewable sources are intermittent in their generation and might compromise the reliability and stability of the distribution network. As a result, energy storage devices, such as batteries and ultra-capacitors, are required to compensate for the variability in the renewable sources. In this paper, a micro grid consisting of a photovoltaic (PV) array, a proton-exchange membrane fuel cell (PEMFC), and a lithium-ion storage battery (SB) is proposed. The PEMFC is used as a backup generator unit to compensate for the power generated by the intermittent nature of the PV array. The SB is implemented for peak shaving during grid-connected operation, and to supply power for any shortage in generated power during islanded operation and to maintain the stability of the distribution network. The proposed controller for the inverters of DG units is based on a newly developed model predictive control (MPC) algorithm, which optimizes the steady-state and the transient control problems separately. In this way, the computation time is greatly reduced. In what follows, this paper provides a comprehensive solution for the operation of a micro grid which will simultaneously dispatch real and reactive power during both grid-connected and islanded operations, compensate for harmonics in the load currents, and perform peak shaving and load shedding under different operating conditions.

II.SYSTEM DESCRIPTION AND MODELING System Description

Fig. 1 shows the configuration of the micro grid proposed in this paper that is designed to operate either in the grid-connected or islanded mode. The main DG unit comprises a 40-kW PV array and a 15-kW PEMFC, which are connected in parallel to the dc side of the DG

inverter 1 through dc/dc boost converters to regulate the dc-link voltage of the DG inverter at the desired level by delivering the necessary power.

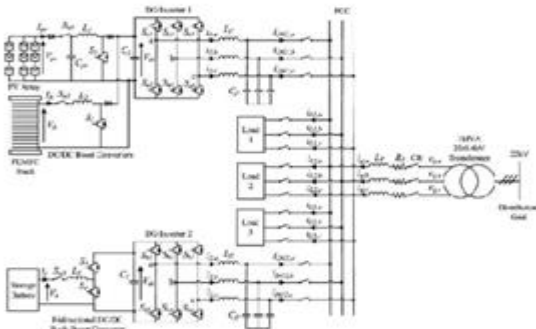

Fig. 1. Overall configuration of the proposed microgrid architecture

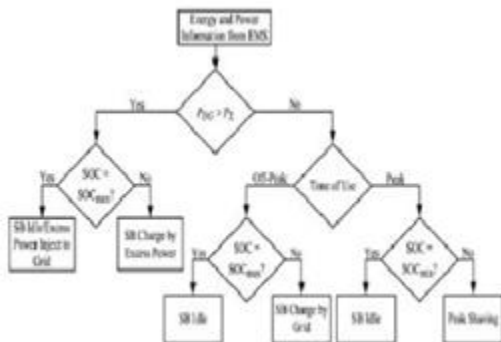

Fig. 2. Operation of the SB during grid-connected operation.

[10], and the output voltage of the PV array is permitted to vary within an allowable range to ensure proper operation of the DG inverter. To maintain the level of the PV array is implemented as the primary generation unit and the PEMFC is used to back up the intermittent generation of the PV array. When there is ample sunlight, the PV array operates in the MPPT mode to deliver maximum dc power P_{PV} , which is discussed in detail in [9] and dc-link voltage V_{dc} at the required level, the PEMFC supplements the generation of the PV array to deliver the necessary Pfc. When the output voltage of the PV array falls below a preset limit, the PV array is disconnected from the DG unit and the PEMFC functions as the main generation unit to deliver the required power. A 30-Ah lithium-ion SB

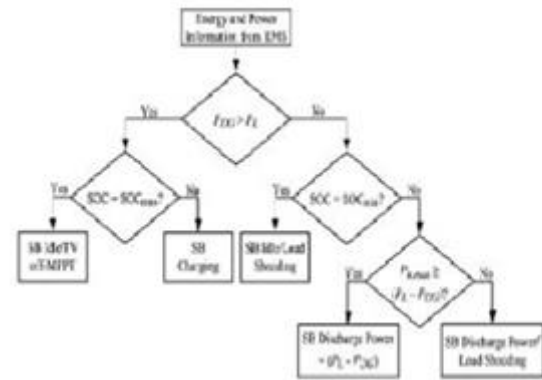

Fig. 4. Equivalent single-phase representation of the DG

Fig. 3. Operation of the SB during islanded operation. is connected to the dc side of DG inverter 2 through a bidirectional dc/dc buck-boost converter to facilitate the charging and discharging operations. During islanded operation, the role of the SB is to maintain the power balance in the micro grid which is given by inverters for grid connected operation. During grid-connected operation, the distribution grid is connected to the micro grid at the point of common coupling (PCC) through a circuit breaker (CB). The role of the main DG unit functions to provide local power and voltage support for the loads and, hence, reduces the burden of generation and delivery of power directly from the distribution grid.

The role of the main DG unit functions to provide local power and voltage support for the loads and, hence, reduces the burden of generation and delivery of power directly from the distribution grid. With the proliferation of power-electronics equipment being connected to the micro grid, the load currents could be distorted due to the presence of harmonic components. The DG units also function to compensate for any harmonics in the currents drawn by nonlinear loads in the micro grid, so that the harmonics will not propagate to other electrical networks connected to the PCC. Generally, there are variations in the power generated by the PV array and that demanded by the loads. If the power generated by the main DG unit is greater than the total load demand in the micro grid, the excess power can be used to charge the SB or injected into the distribution grid, depending on the SOC of the SB, as shown in Fig. 2. Conversely, when the total load demand is greater than the power generated by the main DG unit, the SB can be controlled to achieve different

energy management functions depending on its SOC and the time of use (TOU) of electricity. During off-peak periods as shown in Fig. 2, when the cost of generation from the grid is low and if the SB's SOC is below the maximum SOC limit SOC max, the SB can be charged by the grid and the loads will be supplied by the main DG unit and the grid. During peak periods, when the cost of generation from the grid is high and if the SB's SOC is above the minimum SOC limit SOC min, the SB can deliver power to the grid to achieve peak shaving. When a fault occurs on the upstream network of the distribution grid, the CB operates to disconnect the micro grid from the distribution grid. The main DG unit and the SB are the sole power sources left to regulate the loads. In the case when the generation capacity of the main DG unit is unable to

where u_j is the control input and $j=1, 2$. The output of the DG inverter is interfaced with an LC filter represented by L_{fi} and C_{fi} to eliminate the high switching frequency harmonics generated by the DG inverter. The resistance R_j models the loss of the DG inverter. The total load current i_L , which is the sum of the currents delivered to the load ($k=1, 2, 3$), is given by

$$i_L = \sum_{k=1,2,3} i_{Lk} = i_{L1} + i_{L2} + i_{L3} \quad (4)$$

and can be modeled as two components consisting of fundamental i_{Lf} and harmonic i_{Lh} with their peak amplitudes I_{Lf} and I_{Lh} , respectively, and is represented by

$$\begin{aligned} i_L &= i_{Lf} + i_{Lh} = \\ &= I_{Lf} \sin(\omega t - \varphi_{Lf}) + \sum_{h=2,3,\dots}^N I_{Lh} \sin(h\omega t - \varphi_{Lh}) \\ &= I_{Lf} \sin \omega t \cos \varphi_{Lf} - I_{Lf} \cos \omega t \sin \varphi_{Lf} + \\ &= \sum_{h=2,3,\dots}^N I_{Lh} \sin(h\omega t - \varphi_{Lh}) \\ &= i_{Lfp} + i_{Lfq} + i_{Lh} \end{aligned} \quad (5)$$

where φ_{Lf} and φ_{Lh} are the respective phase angles of the fundamental and harmonic components of i_L , and i_{Lfp} and i_{Lfq} are the instantaneous fundamental phase and quadrature components of i_L . To achieve unity power factor at the grid side, compensate for the harmonics in the load currents and concurrently achieve load sharing, the inverter of the DG unit supplies a current i_{DGj} that is given by]

$$i_{DGj} = (i_{Lfp} - i_g) + i_{Lfq} + i_{Lh} \quad (6)$$

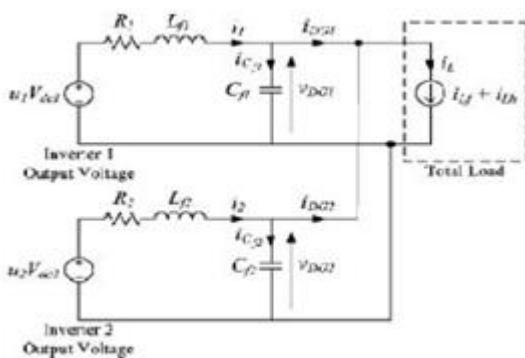

Fig. 5. Equivalent single-phase representation of the DG inverters for islanded operation.

meet the total load demand, the SB is required to provide for the shortage in real and reactive power to maintain the power balance and stability of the micro grid as shown in Fig. 3. When the total load demand exceeds the generation capacity of the main DG unit and the SB, the EMS detects a drop in the system frequency and load shedding for noncritical loads is required to restore the system frequency and maintain the stability of the micro grid

B. DG Inverter Modeling Figs. 4 and 5 show the equivalent single-phase representation of the DG inverters for grid-connected and islanded operation, respectively [13]–[15]. The switched voltage across the output of the i th DG inverter is represented by $u_j V_{dcj}$,

where i_g is the grid current. As shown in Fig. 4, the distribution grid is supplied by a utility substation represented by a voltage source v_g during grid-connected operation, and is connected to the micro grid and the loads the micro grid shares the load demand with the grid. Hence, to control the power delivered to the loads, the output current of the DG inverter is controlled using the current control mode (CCM). During islanded operation, the micro grid will supply the overall load demand as shown in Fig. 5, and it is required that the output voltage be regulated to a pure sine wave with a fixed magnitude. This can be achieved through the voltage-control mode (VCM). The control design for the DG inverter will be elaborated on further in Section III

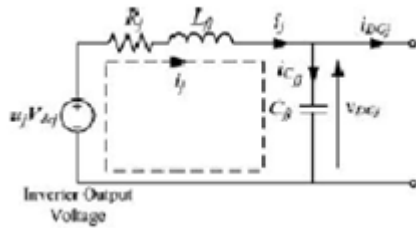

Fig. 6. Single-phase representation of the j th DG inverter for grid-connected and islanded operations.

To derive a state-space model for the DG inverter during both grid-connected and islanded operations, Kirchhoff's voltage and current laws are applied to the current loop i_j as shown in Fig. 6, and the following equations are obtained:

$$\frac{di_j}{dt} = -\frac{R_j}{L_{fj}} i_j - \frac{1}{L_{fj}} v_{DGj} + \frac{v_{dxi}}{L_{fj}} u_j \quad (7)$$

$$\frac{dv_{DGj}}{dt} = \frac{1}{C_{fj}} i_j - \frac{1}{C_{fj}} i_{DGj} \quad (8)$$

Where i_j is the current passing through L_{fj} . Hence, the grid connected DG inverter model can be written as

$$\dot{x}_{gj} = A_{gj} x_{gj} + B_{gj1} v_j + B_{gj2} u_j \quad (9)$$

$$y_{gj} = C_{gj} x_{gj} + D_{gj1} v_j + D_{gj2} u_j \quad (10)$$

where the subscripts and represent the model of DG inverter j during grid-connected operation ($j=1, 2$) and

$$A_{gj} = -\frac{R_j}{L_{fj}}; B_{gj1} = \begin{bmatrix} -\frac{1}{L_{fj}} & 0 \end{bmatrix}; B_{gj2} = \frac{v_{dxi}}{L_{fj}};$$

$$C_{gj} = 1; D_{gj1} = \begin{bmatrix} 0 & -C_{fj} \end{bmatrix}; D_{gj2} = 0$$

x_{gj} is the state; $v_j = [v_{DGj} \quad dv_{DGj}/dt]^T$ is the exogenous input; u_j is the control input, with $-1 \leq u_j \leq 1$; and $y_{gj} = i_{DGj}$ is the output, which will be regulated to track the desired periodic reference waveform.

Adjustable. The decomposition also allows the steady-state During islanded operation, the frequency will change due to power imbalance in the micro grid. This change in frequency is detected by the EMS of the micro grid, which is used to manage and monitor the power dispatch by each DG unit. Based on the frequency change

information, the EMS will require the main DG unit and the SB to generate the necessary power to meet the overall load demand in the micro grid as shown in the flowchart of Fig. 3, such that (1) is satisfied. During islanded operation, it follows from (7) and (8) that DG inverter can be modeled as

$$\dot{x}_{ij} = A_{ij} x_{ij} + B_{ij1} i'_j + B_{ij2} u_j \quad (11)$$

$$y_{ij} = C_{ij} x_{ij} + D_{ij1} i'_j + D_{ij2} u_{j2} \quad (12)$$

where the subscript denotes the model of the DG inverter during islanded operation ($j=1, 2$) and

$$A_{ij} = \begin{bmatrix} -\frac{R_j}{L_{fj}} & -\frac{1}{L_{fj}} \\ \frac{1}{C_{fj}} & 0 \end{bmatrix}; B_{ij1} = \begin{bmatrix} 0 \\ -\frac{1}{C_{fj}} \end{bmatrix}; B_{ij2} = \begin{bmatrix} \frac{v_{dxi}}{L_{fj}} \\ 0 \end{bmatrix}$$

$$C_{ij} = \begin{bmatrix} 0 & 1 \\ 1 & -\frac{C_{fj}}{C_{fj}} \end{bmatrix}; D_{ij1} = \begin{bmatrix} 0 \\ \frac{C_{fj}}{C_{fj}} \end{bmatrix}; D_{ij2} = \begin{bmatrix} 0 \\ 0 \end{bmatrix}$$

with x_{ij} is the state vector; v_j is the exogenous input of the DG inverter; u_j is the control input, with $-1 \leq u_j \leq 1$; and y_{ij} is the output, which will be regulated to track the desired reference waveform. Note that although the emphasis is on the voltage v_{DGj} , both v_{DGj} and i_{DGj} will be regulated in the VCM to ensure that the power is delivered. Furthermore, it is assumed that the exogenous input i'_j in the model is not directly measurable by the DG inverter since it involves quantities outside that inverter. Precisely, i'_j represents the sum of all load currents i_L minus the sum of all from the other DG inverters in the micro grid. Although only one other inverter has been presented in the proposed micro grid, the model is extendable to more DG inverters.

III. CONTROL DESIGN

With the mathematical model presented in Section II-B, this paper proposes a novel MPC algorithm for the control of the DG inverters of the micro grid. The proposed algorithm is a newly developed MPC algorithm specifically designed for fast-sampling systems, to track periodic signals so as to deal with the dual-mode operation of the micro grid. The algorithm decomposes the MPC optimization into a steady-state sub-problem and a transient sub-problem, which can be solved in parallel in a receding horizon fashion. Furthermore, the

steady-state sub problem adopts a dynamic policy approach in which the computational complexity is sub-problem to be solved at a lower rate than the transient sub-problem if necessary. These features help to achieve a lower computational complexity and make it suitable for implementation in a fast-sampling system like our micro grid applications. In the simulation studies in this paper, the sampling interval is chosen as 0.2ms, which is considered pretty small in conventional MPC applications, but necessary for the high order of harmonics being tackled for our problem. According to [16], sampling in the range of tens of kHz is possible with state-of-the-art code generation techniques. It is noted that in either the grid-connected or the islanded operation, the state-space model of Section II-B after time-discretization will take the form

$$x^+ = Ax + B_1 w + B_2 u \quad (13)$$

$$y = Cx + D_1 w + D_2 u \quad (14)$$

Desired active and reactive power outputs of the DG units generated by the EMS. On the other hand, for the VCM as described in Section II-B during islanded operation, for the DG unit and the reference consists of a voltage reference and a current reference. The voltage reference for to track is typically a pure sine wave, which is derived from the monitored prior to islanding. To ensure that the respective DG units deliver the necessary power for stable operation of the micro grid during islanded operation, the current reference for to track is regulated according to the power reference generated by the EMS. The state-space model given by (15)–(17) is known as the exogenous system in this paper. Although only odd harmonics up to the 29th order have been considered, the methodology can be easily extended to include even harmonics. The exogenous state ξ , which essentially represents the sets of Fourier coefficients of ω and d , can be automatically identified using a Kalman-based observer known as the exogenous Kalman filter once the signal ω is measured and the reference is specified. The exogenous Kalman filter is given by

where the superscript $+$ represents the time-shift operator (with sampling interval T_s), and the exogenous signal ω is periodic. In general, any periodic signal with a finite number of harmonics can be written as the output of an autonomous finite-dimensional linear time-invariant state-space model. For example, if the periodic signal has a fundamental frequency ω and consists of only odd harmonics, the A -matrix of the corresponding state-space model can take a block diagonal form with the blocks given by $\begin{bmatrix} \cos(h\omega T_s) & \sin(h\omega T_s) \\ -\sin(h\omega T_s) & \cos(h\omega T_s) \end{bmatrix}$ where $h=1,3,5,\dots$, and the C -matrix $[1 \ 0 \ 1 \ 0 \ \dots \ 1 \ 0]$. Furthermore, the initial state of this autonomous model determines the magnitude and phase angle of this periodic signal. Hence, the exogenous signal ω in (13) and (14) together with the reference that y in (14) desires to track can be modeled by

$$\xi^+ = A_\xi \xi \quad (15)$$

$$\omega = C_\omega \xi \quad (16)$$

$$d = C_d \xi \quad (17)$$

for some A_ξ , C_ω and C_d as described above. For the CCM during grid-connected operation, $y=i_{DG}$ and the current reference $d=i_{DG}$ for i_{DG} to track consist of the same order of harmonics as i_{DG} and is derived from the

A. Steady-State Sub problem The control objective of the steady-state subproblem is to identify an optimal control signal u such that when $u \rightarrow u_s$ asymptotically and, thus, $x \rightarrow x_s$ and $y \rightarrow y_s$, the steady-state output y should be as close to the desired reference as possible. According to (13) and (14), u_s , x_s and y_s should satisfy

$$\xi^+ = A_\xi \xi + L_\omega (\omega - \hat{\omega}) + L_d (d - \hat{d}) \quad (18)$$

$$\hat{\omega} = C_\omega \xi \quad (19)$$

$$\hat{d} = C_d \xi \quad (20)$$

Where ξ is the estimated exogenous state, L_ω and L_d are the observer gain matrices of the Kalman filter, and the terms $(\omega - \hat{\omega})$ and $(d - \hat{d})$ are essentially the difference between the actual ω , d and the estimated $\hat{\omega}$, \hat{d} generated from the Kalman filter, such that $(\omega - \hat{\omega})$ and $(d - \hat{d})$ should tend to zero asymptotically. Since ξ is actually a Fourier decomposition of the periodic signals ω and d , the exogenous Kalman filter given by (18)–(20) functions like a harmonic extraction circuit from the power system point of view [17], [18].

In what follows, the control in (13) and (14) is decomposed into a steady-state control u_s and a transient control u_t as

$$u = u_s + u_t \quad (21)$$

such that $u_t \rightarrow 0$ and $u_s \rightarrow u_s$ asymptotically. Both u_s and u_t will employ a MPC strategy, but the former will adopt a dynamic MPC policy whereas the latter will adopt a more conventional finite-horizon approach.

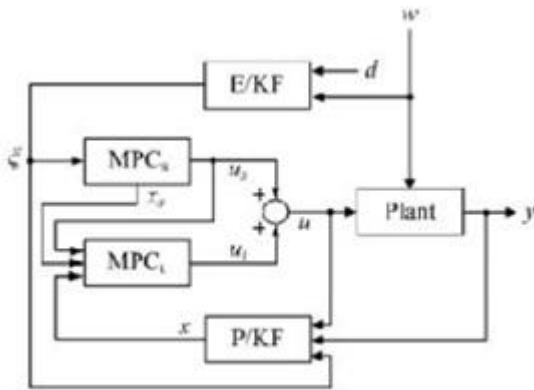

Fig. 7. Overall MPC controller for the DG inverter with E/KF denoting the exogenous Kalman filter and P/KF denoting the plant Kalman filter.

$$x_z^* = Ax_z + B_1 \omega + B_2 u \quad (22)$$

$$y_z = Cx_z + D_1 \omega + D_2 u \quad (23)$$

subject to the constraint that

$$|u_z| \leq 1 \quad (24)$$

We consider the steady-state control being generated from a dynamic MPC policy

$$\xi^* = A_\xi \xi \quad (25)$$

$$u_s = C_\xi \xi \quad (26)$$

where the matrices A_ξ and C_ξ are designed offline but the initial state ξ at time k will be optimized online to minimize a quadratic penalty on the tracking error $\xi_k = x_k - d$ in a receding horizon fashion.

B. Transient Subproblem

Once the optimal u_s , $x_{s,k}$ and $y_{s,k}$ are identified by the steady-state subproblem, the control objective of the transient subproblem is to ensure that the transient signals $u_t = u - u_s$, $x_t = x - x_{s,k}$ and $y_t = y - y_{s,k}$ go to zero promptly. Then according to (13)

and (14), and (22) and (23), u_t , x_t and y_t should satisfy

$$x_t^* = Ax_t + B_2 u_t \quad (27)$$

$$y_t = Cx_t + B_2 u_t \quad (28)$$

In this transient sub problem, the objective is to make $y_t \rightarrow 0$ as fast as possible, subject to the constraint

$$|u_s + u_t| \leq 1. \quad (29)$$

A conventional approach of MPC that employs a finite horizon with a terminal cost can be adopted. It requires the information of u_t and $x_{s,k}$, which will be provided by the solution of the steady-state subproblem, and the information of the plant state x , which can be estimated using a plant Kalman filter on (13) and (14). Similar to the case of the exogenous Kalman filter, the plant Kalman filter is given by

$$\hat{x}^* = A\hat{x} + B_1 \omega + B_2 u + L_y (y - \hat{y}) \quad (30)$$

$$\hat{y} = C\hat{x} + D_1 \omega + D_2 u \quad (31)$$

Where \hat{x} is the estimated plant state and L_y is the observer gain matrix of the plant Kalman filter, and the term $(y - \hat{y})$ is the difference between the actual measured output y and the estimated output \hat{y} . The overall configuration of the proposed control algorithm combining the steady-state control u_s and the transient control u_t is shown in Fig. 7.

SIMULATION STUDIES

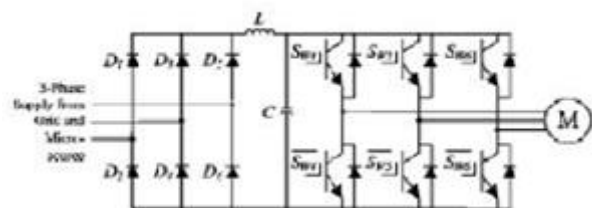

Fig. 8. Configuration of a 15-kVA three-phase ASD.

The simulation model of the micro grid shown in Fig. 1 is realized in Matlab/Simulink. The micro grid is tested under various conditions to evaluate its capabilities when operating connected and islanded from the distribution grid. Three different load types consisting of linear and nonlinear loads are considered in the studies. For load 1,

a 15-kVA three-phase PWM adjustable speed drive (ASD) with its configuration as shown in Fig. 8 is used and load 2 is made up of a three-phase RL load rated at $PL_2= 28 \text{ kW}$ and $QL_2=18.5 \text{ kVAr}$. Load 3 is a noncritical three phase dimmer load rated at $PL_3=18 \text{ kW}$ and $QL_3=12.3 \text{ kVAr}$, which is nonlinear in nature and will be shed under emergency conditions when the generation of the micro grid is unable to meet the load demand. The per-phase currents i_{L1} , i_{L2} , and i_{L3} drawn by loads 1, 2, and 3 for s are shown in Fig. 9. The system parameters are given in Table I. The impedances of the DG inverters and distribution line have been coarsely estimated since these values are not precisely known in practice.

The first test case demonstrates the capability of the micro grid to improve the power quality of the distribution network by compensating for the harmonics in the total load current i_L due to the nonlinear loads that are connected to the distribution network, such that the harmonics will not propagate to the rest of the distribution network during grid-connected operation. In this test case, the main DG unit accounts for 20% of the total load demand. The SB is operating in the charging mode to store energy during off peak period where the cost of generation from the grid is low to meet future sudden demands for power. The SB current (as shown in Fig. 1) and the SOC during charging for $< 0.4 \text{ s}$ are shown in Figs. 10 and 11, respectively.

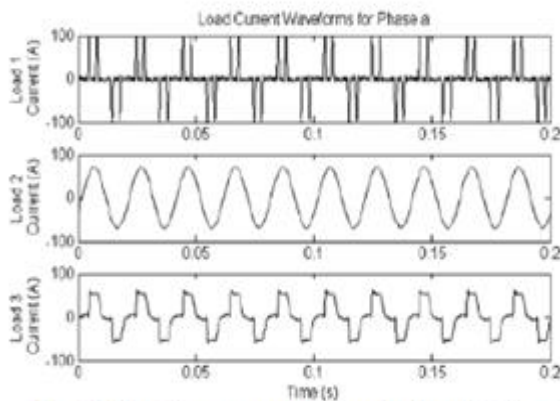

Fig. 9. Per-phase currents drawn by loads 1, 2, and 3.

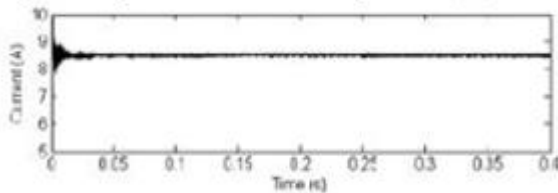

Fig. 10. Waveform of the SB current during charging.

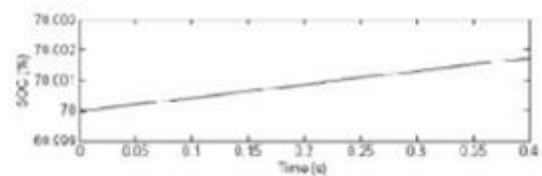

Fig. 11. SOC of the SB during charging.

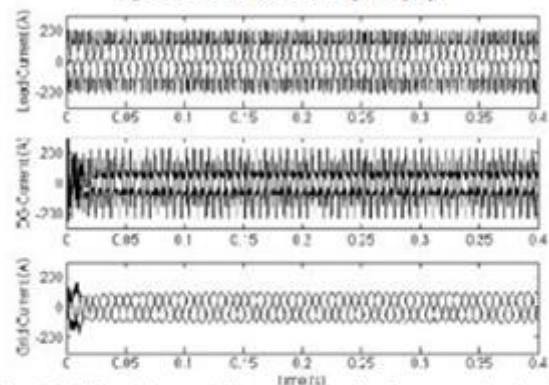

Fig. 12. Waveforms of three-phase load current i_L (top), three-phase DG current i_{DG} (middle), and three-phase grid current i_G (bottom).

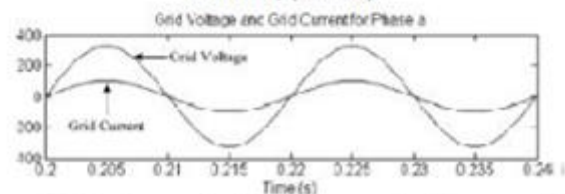

Fig. 13. Waveforms of grid voltage v_G and grid current i_G for phase a.

TABLE I PARAMETERS OF THE PROPOSED SYSTEM	
Parameter	Value
Distribution grid voltage	$V_g=230\text{V}(\text{phase})$
DC link voltage	$V_{dc}=400\text{V}$
Distribution line impedance	$R_f=0.0075\Omega, L_l=25.75\mu\text{H}$
LC filter	$L_f=1.2\text{mH}, C_f=20\mu\text{F}$
DG inverter loss resistance	$R_f=0.01\Omega$

A. Test Case 1: Power Quality Improvement With Load-Sharing During Grid-Connected Operation

The waveforms of the total load current i_L , the current supplied by the main DG unit i_{DG} and grid current i_G under this test case are shown in Fig. 12. The unsteady measurements in i_{DG} and as shown in Fig. 12(middle) and Fig. 12(bottom) respectively during initialization for

< 0.06 s are due to the fact that the controller needs a period of 3 cycles to track the generated references. During steady state condition, the total harmonic distortion (THD) value of i_L is 42.1% as shown in Fig. 12 (top). With the main DG unit compensating for the harmonic currents as shown in Fig. 12 (middle), the THD value of i_L is improved to about 0.4% as shown in Fig. 12 (bottom). To achieve power factor correction at the grid side, the main DG unit is also controlled to provide the reactive component $i_{L,q}$ of the current i_L as given in (5). Fig. 13 shows closed-up waveforms of the grid voltage v_g and i_g of phase a for . It is observed that the waveform of i_g is in phase with that of v_g with power factor correction the reactive power supplied by the grid is zero, resulting in unity power factor at the grid side.

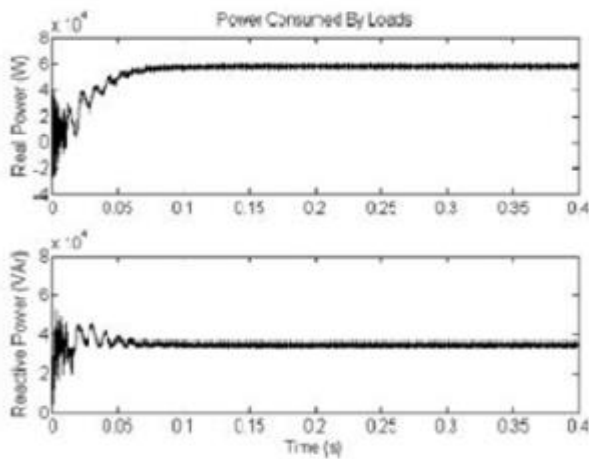

Fig. 14. Real (top) and reactive (bottom) power consumed by loads.

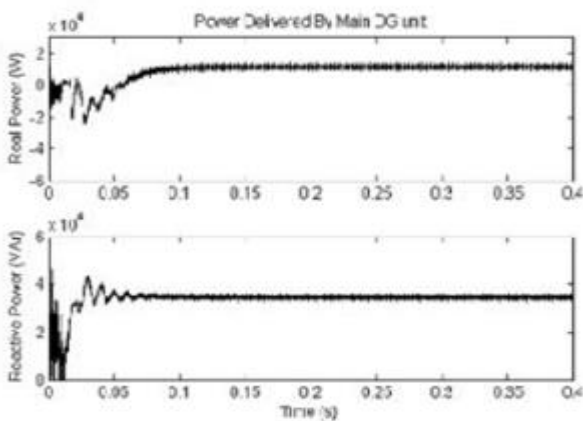

Fig. 15. Real (top) and reactive (bottom) power delivered by the main DG unit. B. Test Case 2: Peak Shaving of Loads During Peak Periods The electricity pricing in many countries is impacted by the TOU tariffs. In DSM, energy-storage devices can be used to reduce the burden of generation of power directly from the distribution grid during peak periods. The second test case demonstrates the operation of the micro grid to achieve peak shaving in order to reduce the cost of generation from the grid when consumers practice DSM. Fig. 17 shows a typical hourly demand response curve in a day indicated by the solid line.

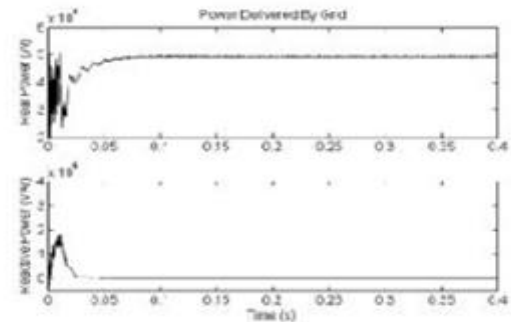

Fig. 16. Real (top) and reactive (bottom) power delivered by the grid.

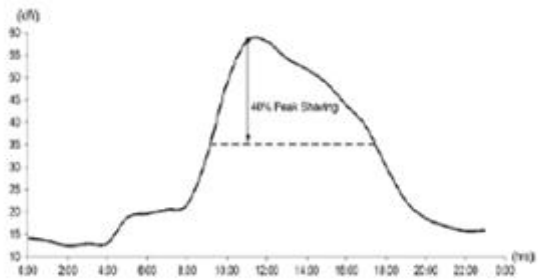

Fig. 17. Hourly demand response curve.

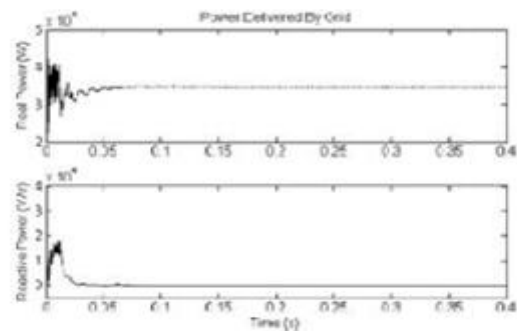

Fig. 18. Real (top) and reactive (bottom) power delivered by the grid.

As in test case 1, the main DG unit is controlled to deliver 20% of the load demand. To achieve peak shaving at 11:00 h, the SB is operating in the discharge mode to provide 20% (11.6 kW) of the load demand. With a further reduction of 20% in the power supplied by the grid, the total load demand at 11:00 h is reduced by a total of 40% as shown by the dotted line in Fig. 17.

The power waveforms of the grid for $t < 0.4$ s are shown in Fig. 18. It can be seen from Fig. 18 that the real power delivered by the grid is 60% (34.8 kW) of the load demand with peak shaving, and the reactive power supplied is zero with the main DG unit compensating for the reactive components of the load currents. The real power waveform delivered by DG inverter 2 (as shown in Fig. 1) of the SB during discharging is shown in Fig. 19. It can be observed from Fig. 19 that the SB delivers the required real power of about 20% (11.6 kW) of the load demand during peak shaving

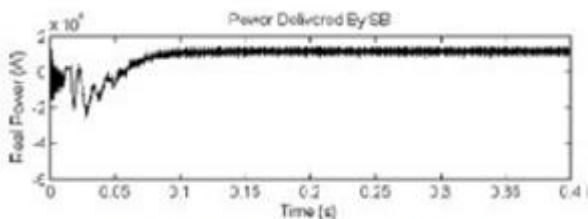

Fig. 19. Real power delivered by SB.

C.Test Case 3: Load Shedding During Islanded Operation During islanded operation, the total generation of the micro grid might not be able to sustain its generation to meet the power demand of the loads. Under such circumstances, consumers participating in DRM will allow the non-critical load to be shed so as to maintain the stable operation of the micro grid. The third test case demonstrates the operation of the micro grid when it islands from the grid. In this test case, the micro grid is initially operating in the grid-connected mode for $t < 0.2$ s. The SB is initially operating in the idle mode and its SOC is 80%. A fault occurs on the upstream network of the distribution grid and the CB operates to disconnect the micro grid from the distribution grid at $t=0.2$ s.

Fig. 20. Real (top) and reactive (bottom) power delivered by the grid.

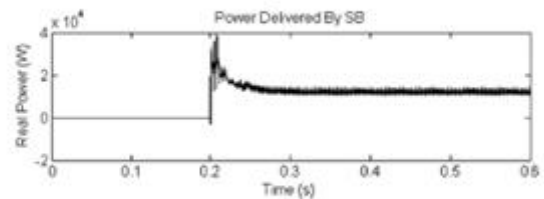

Fig. 21. Real power delivered by SB.

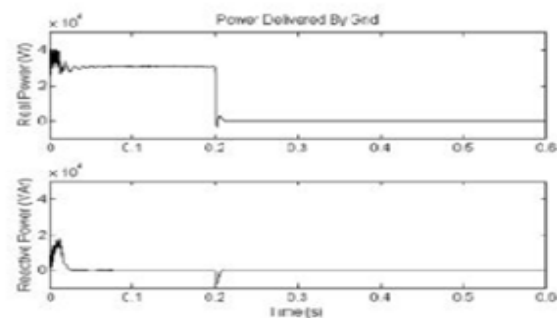

Fig. 20 shows the waveforms of the real and reactive power supplied by the grid. It can be seen from Fig. 20 that the CB manages to fully isolate the micro grid from the distribution grid in about half a cycle, resulting in zero real and reactive power delivered by the grid for $0.2 < 0.6$ s. The real power delivered by DG inverter 2 of the SB is shown in Fig. 21. For $0 < 0.2$ s, the SB is in the idle mode. After the initiation of the islanding operation at $t=0.2$ s, the DG inverter 2 is tasked by the EMS to increase its generation to provide real power of about 12.5 kW to the loads which reach steady-state operation in about 3 cycles. With only the main DG unit and the SB supplying for the loads, the power imbalance results in a decrease in the system frequency, which is detected by the EMS. To maintain the stability of the micro grid during islanded operation, the shedding of load 3 ($PL_3=18$ kW and $QL_3=12.3$ kVAr) is also initiated at $t=0.4$ s by the EMS such that the total generation from the main DG unit ($PDG=27.5$ kW and $QDG=22.7$ kVAr) and the SB ($P_b=12.5$ kW) can meet the power demand by the loads. A delay of 0.2 s is introduced between islanding of the micro grid and load shedding to cater for frequency transients that might occur momentarily due to the energization of large motor loads. The waveforms of the real and reactive power delivered to the loads for $0 < 0.6$

s are shown in Fig. 22. It can be observed from Fig. 22 that when load 3 is shed at $t=0.4$ s, the total real and reactive power delivered to the loads gradually decreases to settle and operate stably at about 40 kW and 22.7 kVAr, respectively, in about 3 cycles.

CONCLUSION

In this paper, a control system that coordinates the operation of multiple DG inverters in a micro grid for grid connected and islanded operations have been presented. The proposed controller for the DG inverters is based on a newly developed MPC algorithm which decomposes the control problem into steady-state and transient sub problems in order to reduce the overall computation time. The controller also integrates Kalman filters into the control design to extract the harmonic spectra of the load currents and to generate the necessary references for the controller. The DG inverters can compensate for load harmonic currents in a similar way as conventional compensators, such as active and passive filters, and, hence, no additional equipment is required for power-quality improvement. To realize the smart grid concept, various energy-management functions, such as peak shaving and load shedding, have also been demonstrated in the simulation studies. The results have validated that the microgrid is able to handle different operating conditions effectively during grid-connected and islanded operations, thus increasing the overall reliability and stability of the micro grid.

REFERENCES

- [1] S. Braithwait, "Behaviormanagement," IEEE Power and EnergyMag., vol. 8, no. 3, pp. 36–45, May/Jun. 2010.
- [2] N. Jenkins, J. Ekanayake, and G. Strbac, Distributed Generation. London, U.K.: IET, 2009.
- [3] M. Y. Zhai, "Transmission characteristics of low-voltage distribution networks in China under the smart grids environment," IEEE Trans. Power Del., vol. 26, no. 1, pp. 173–180, Jan. 2011.
- [4] G. C. Heffner, C. A. Goldman, and M. M. Moezzi, "Innovative approaches to verifying demand response of water heater load control," IEEE Trans. Power Del., vol. 21, no. 1, pp. 1538–1551, Jan. 2006.
- [5] R. Lasseter, J. Eto, B. Schenkman, J. Stevens, H. Vollkommer, D. Klapp, E. Linton, H. Hurtado, and J. Roy, "Certs microgrid laboratory test bed, and smart loads," IEEE Trans. Power Del., vol. 26, no. 1, pp. 325–332, Jan. 2011.
- [6] A. Molderink, V. Bakker, M. G. C. Bosman, J. L. Hurink, and G. J. M. Smit, "Management and control of domestic smart grid technology," IEEE Trans. Smart Grid, vol. 1, no. 2, pp. 109–119, Sep. 2010.
- [7] A. Mohsenian-Rad, V. W. S.Wong, J. Jatskevich, R. Schober, and A. Leon-Garcia, "Autonomous demand-side management based on gametheoretic energy consumption scheduling for the future smart grid," IEEE Trans. Smart Grid, vol. 1, no. 3, pp. 320–331, Dec. 2010
- [8] S. Chowdhury, S. P. Chowdhury, and P. Crossley, Microgrids and Active Distribution Networks. London, U.K.: IET, 2009.
- [9] A. Yazdani and P. P. Dash, "A control methodology and -connected and stand-alone applications," in characterization of dynamics for a photovoltaic (PV) system interfaced with a distribution network," IEEE Trans. Power Del., vol. 24, no. 3, pp. 1538–1551, Jul. 2009.
- [10] K. T. Tan, P. L. So, Y. C. Chu, and K. H. Kwan, "Modeling, control and simulation of a photovoltaic power system for gridProc. Int. Power Energy Conf., 2010, vol. 56, pp. 608–613.
- [11] M. Charkhgard and M. Farrokhi, "State-of-charge estimation for lithium-ion batteries using neural networks and EKF," IEEE Trans. Ind. Electron., vol. 57, no. 12, pp. 4178–4187, Jun. 2010.
- [12] M. Coleman, C. K. Lee, C. Zhu, and W. G. Hurley, "State-of-charge determination from EMF voltage estimation: Using impedance, terminal voltage, and current for lead-acid and lithium-ion batteries," IEEE Trans. Ind. Electron., vol. 54, no. 5, pp. 2550–2557, Oct. 2007.
- [13] A. Gosh and G. Ledwich, Power Quality Enhancement Using Custom Power Devices. Norwell, MA: Kluwer, 2002, pp. 380–406.



[14] J.M.Guerrero, J. Matas, L. Garcíade Vicuña, M. Castilla, and J.Miret, “Decentralized control for parallel operation of distributed generation inverters using resistive output impedance,” *IEEE Trans. Ind. Electron.*, vol. 54, no. 2, pp. 994–1004, Apr. 2007.

[15] C. L. Chen, Y. B.Wang, J. S. Lai, Y. S. Lai, and D. Martin, “Design of parallel inverters for smooth mode transfer of microgrid applications,” *IEEE Trans. Ind. Electron.*, vol. 25, no. 1, pp. 6–15, Jan. 2010.

[16] J. Mattingley, Y. Wang, and S. Boyd, “Receding horizon control: Automatic generation of high-speed solvers,” *IEEE Control Syst. Mag.*, vol. 31, no. 3, pp. 52–65, Jun. 2011

[17] J. A. Macias and A. Gomez, “Self-tuning of Kalman filters for harmonic computation,” *IEEE Trans. Power Del.*, vol. 21, no. 1, pp. 501–503, Jan. 2006.

[18] V. Moreno, A. Pigazo, and R. I. Diego, “Reference estimation technique for active power filters using a digital Kalman algorithms,” in *Proc. Int. Conf. Harmonics Qual. Power*, 2002, vol. 2, pp. 490–494, 1.