

## Indirect Vector Control of Induction Motor Drive using Fuzzy Controller

S Sahitni

Department of Electrical and Electronics  
Engineering,

Andhra University,

Visakhapatnam, Andhra Pradesh 530003, India.

R. Srinu Naik

Department of Electrical and Electronics  
Engineering,

Andhra University,

Visakhapatnam, Andhra Pradesh 530003, India.

### Abstract

*In this paper a model-predictive flux control (MPFC), which uses the stator flux vector as the control variable with is used as a predictive control. Induction motor modelling is done by using dq transformations. In this project, a modular simulink implementation of an induction machine model is described in a step-by-step approach. With the modular system, each block solves one of the model equations. Therefore, unlike black box models all of the machine parameters are accessible for control and verification purposes. A vector control model is developed for induction motor using speed and flux as reference. Fuzzy control based model reference adaptive control (MRAC) is developed for speed estimation. The total system is carried out in matlab simulink software.*

**Index Terms**— induction motor. MPFC, MRAC, FUZZY control.

### I. Introduction

Variable speed drives or adjustable torque control of electrical motor drives are crucial components in almost all-modern industrial manufacturing processes.

Traditionally variable speed electric machines were based on dc motors, but for 20 years, the inverter fed ac drives has largely taken over as the preferred solution for variable speed applications. For low performance application, open loop constant V/Hz control strategies are employed. Considering high performance motion control, field oriented control, or more recently direct torque control are used.

Usually, when an electrical machine is simulated in circuit simulators like Pspice, its steady state model is used, but for electrical drives studies, the transient behavior is also important. One advantage of simulink over circuit simulators is the ease in modeling the transients of electrical machines and drives and to include drive controls in the simulation.

As long as the equations are known, any drive or control algorithm can be modeled in simulink. However, the equations by themselves are not always enough; some experience with differential equation solving is required. Simulink induction machine models are available in the literature [1-3], but they appear to be black boxes with no internal details. Some of them [1-3] recommended using simulink S-functions, which are software source codes for simulink blocks. This technique does not fully utilize the power and ease of simulink because S-function programming knowledge is required to access the model parameters or variables. S-functions run faster than discrete simulink blocks, but simulink models can be made to run faster using “accelerator” functions or producing stand-alone simulink models. Both of these require additional expense and can be avoided if the simulation speed is not that critical. Another approach is using the simulink power system block set that can be purchased with simulink. This block set also makes use of S-functions and is not easy to work with as the rest of the simulink blocks.

**Cite this article as:** S Sahitni & R. Srinu Naik, "Indirect Vector Control of Induction Motor Drive using Fuzzy Controller", International Journal & Magazine of Engineering, Technology, Management and Research, Volume 5 Issue 9, 2018, Page 45-51.

Reference [5] refers to an implementation approach similar to the one in this project but fails to give details.

## II. INDUCTION MACHINE MODEL

There are numerous ways of formulating the equations of an induction machine for the purpose of computer simulation.

In particular, the computer representation of the symmetrical induction machine in the arbitrary reference frame will be used as the basis from which various modes of operation are represented. This simulation is quite convenient not only from the standpoint of representing all practical modes of operation but this form also permits the effects of saturation to be readily simulated. Moreover, with slight modifications, this basic simulation may be used to represent unsymmetrical induction machines and some reduced order models of symmetrical induction machines.

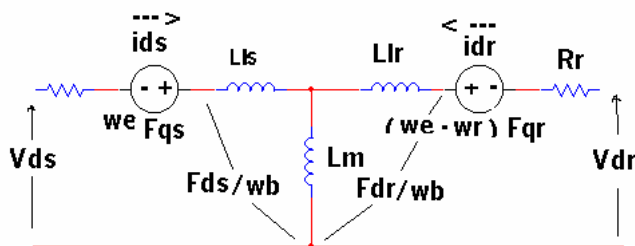

**Fig. 1** Dynamic or d-q equivalent circuit of an induction machine at synchronously rotating reference frame.

One of the most popular induction motor models derived from this equivalent circuit is Krause's model detailed in reference [6].

According to his induction machine model the modeling equations in the flux linkage form are as follows.

$$\frac{dF_{qs}}{dt} = (\omega_b/p) * [v_{qs} - (\omega/\omega_b) * F_{ds} + (r_s/X_{ls}) * (F_{mq} - F_{qs})] \quad (1)$$

$$\frac{dF_{ds}}{dt} = (\omega_b/p) * [v_{ds} + (\omega/\omega_b) * F_{qs} + (r_s/X_{ls}) * (F_{md} - F_{ds})] \quad (2)$$

$$\frac{dF_{qr}}{dt} = (\omega_b/p) * [v_{qr} - ((\omega - \omega_r)/\omega_b) * F_{dr} + (r_r/X_{lr}) * (F_{mq} - F_{qr})] \quad (3)$$

$$\frac{dF_{dr}}{dt} = (\omega_b/p) * [v_{dr} + ((\omega - \omega_r)/\omega_b) * F_{qr} + (r_r/X_{lr}) * (F_{md} - F_{dr})] \quad (4)$$

### 1.2.1 2.1 Commonly used reference frames

The behavior of the induction machine may be described in any frame of reference. There are three main frames which are commonly used. Namely the stationary reference frame, the rotor reference frame and the synchronously rotating reference frame. The voltage equations for each of these reference frames may be obtained from the voltage equations in the arbitrary reference frame by assigning the appropriate speed to  $\omega$ . That is,  $\omega=0$  for the stationary reference frame.  $\omega=\omega_r$  for the rotor reference frame and  $\omega=\omega_e$  for the synchronously rotating reference frame.

Generally, the conditions of operation will determine the most convenient reference frame for analysis and computer simulation purposes.

For example, the stator voltages are unbalanced or discontinuous and the rotor applied voltages are balanced or zero then the stationary reference frame should be used to simulate the performance of the induction machine. If, on the other hand the external rotor circuits are unbalanced but the applied stator voltages are balanced, then the reference frame fixed in the rotor is most convenient. Either the stationary or the synchronously rotating reference frame is generally used to analyze the balanced or symmetrical conditions.

The synchronously rotating reference frame is also particularly convenient when incorporating the dynamic characteristics of an induction machine into a digital computer program used to study the transient and dynamic stability of large power systems.

The synchronously rotating reference frame may also be useful in variable frequency applications if it is permissible to assume that the stator voltages are a balanced sinusoidal set. In this case variable frequency operation may be analyzed by varying the speed of the arbitrary reference frame to coincide with the electrical angular velocity of the applied stator voltages. Regardless of the reference frame being used the stator

and rotor voltages and current must be properly transformed to and this reference frame.

### 3 INDIRECT VECTOR CONTROL OPERATIONS

In this indirect method of vector control, we need stator currents as well as the rotor speed or position. The induction machine model directly gives these.

A rotor slip calculation is used to find the slip speed that is integrated to give the slip position. By adding this to the rotor position measurement gives the rotor flux position and, hence the unit vectors required to transform between the stationary frame and rotating frame quantities.

The differential equations that describe the calculation of the slip position are as follows.

$$d|\Psi_r|/dt = (r_r/l_r)(L_m \cdot i_{ds} - |\Psi_r|) \quad \text{-----5}$$

$$d\theta_{sl}/dt = \omega_{sl} = (L_m \cdot r_r / |\Psi_r| \cdot L_r) \cdot i_{qs} \quad \text{-----6}$$

The actual position of the rotor flux is found by integrating the calculated slip speed and the adding the resultant slip angle to the rotor angle

$$\theta_{sl} = \int \omega_{sl} dt \quad \text{----- 7}$$

$$\theta_e = \theta_{sl} + \theta_r \quad \text{----- 8}$$

The flux position given by  $\theta_e$  is then used to calculate the quadrature unit vectors  $\cos \theta_e$  and  $\sin \theta_e$ . The stator currents are

In this method, a sinusoidal voltage signal of frequency ( $f_m$ ), having a peak ( $V_m$ ) is compared with a high frequency triangular carrier of frequency ( $f_c$ ) having a peak voltage ( $V_c$ ). The natural points of intersections or these two signals determine the instants for the power devices of the inverter.

Whenever the reference sinusoidal wave is greater than the carrier, pulse is generated which turns on the upper transistor of the half –bridge inverter and the lower transistor in the same leg is turned off. Other wise, a notch is generated which turns on the lower transistor of the half bridge inverter and the upper transistor in the same leg is turned off. Here the sine wave is said to be modulating the carrier wave (triangular) in such a manner that the output phase voltages have higher fundamental component. The same principle is extending to the three phase inverter with the additional characteristics that the modulating sine waves are shifted by 120 degrees for the other legs of the inverter. The harmonic content is dependent on the frequency ratio

$$mf = f_c / f_m$$

The ratio of the peak of the modulating signal to the peak of carrier signal is called modulating index ‘ma’ where

$$ma = V_m / V_c$$

The inverter phase to dc center tap voltage can be analyzed and it can be shown that, the output voltage fundamental component is linearly related to the modulating index.

$$V(t) = ma V_{dc} / 2 \sin(W_m t + \phi) + \text{Bessel function harmonic terms.}$$

Where  $ma$  = modulation index

$W_m$  = fundamental frequency (same as the modulating frequency)

$\phi$  = Phase shift of the output depending on the position of the modulating wave.

The peak value of the fundamental is maximum when  $ma = 1$  and is equal to  $V_{dc} / 2$ . if we compare this value with that of square wave mode of operation for ( $ma > 1$ )

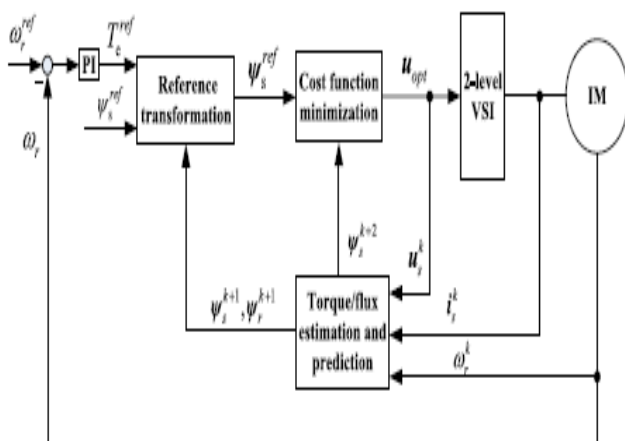

Fig 2 Vector control of induction motor

### 4 Sinusoidal Pulse Width Modulation

,the maximum fundamental voltage obtained in the sine triangle method is 78.5%.

Usually  $f_c$  is chosen such that it is an integral multiple of  $f_m$ , that is  $f_c = m_f * f_m$ ; where  $m_f$  is an integer. The voltage harmonics are of frequency  $m(f_c) + n(f_m)$ , where  $m$  and  $n$  are integers, and  $m + n$  is an odd integer. This means that the lower harmonics are shifted to values of frequencies near  $f_c, 2f_c, 3f_c$  etc. this is shown in figure. If  $m_f$  is chosen to be an odd multiple of three, then all even and triplen harmonics are eliminated. The impedance of the machine to these harmonics will be high and they will not cause appreciable disturbances and losses. The amount to which dominant harmonics will shift depend on value of  $m_f$ . Higher its value, smaller will be the lower order harmonic content and smoother will be the current wave form. If  $m_f$  is made high, inverter-switching losses become considerable. So that one has to find out a value of  $m_f$  so as to optimize the total losses and to retain the quality of performance throughout the range of speed control. A single value of  $m_f$  cannot satisfy the constraints, because for lower frequencies, the lower order harmonics must be shifted far to avoid undesirable effects associated with harmonics. Therefore it is necessary to keep the value of  $m_f$  high at low frequency and as frequency increase  $m_f$  should be reduced so as to reduce the switching losses.

### MRAC observer

The scheme is based on the fact that one observer estimates the rotor flux and the speed are derived by the stator current error and the estimated rotor flux. In terms of classification, the scheme that adopts an observer could be also treated as MRAS, where the motor is considered as the reference model and the observer is considered as the adjustable model.

The IM model in terms of state variables in stationary reference frame is given as follows:

$$\frac{d}{dt} \begin{bmatrix} \bar{i}_s \\ \bar{\psi}_r \end{bmatrix} = \begin{bmatrix} A_{11} & A_{12} \\ A_{21} & A_{22} \end{bmatrix} \begin{bmatrix} \bar{i}_s \\ \bar{\psi}_r \end{bmatrix} + \begin{bmatrix} B_1 \\ 0 \end{bmatrix} \bar{v}_s = A \begin{bmatrix} \bar{i}_s \\ \bar{\psi}_r \end{bmatrix} + B \bar{v}_s \dots \dots \dots (1)$$

$$\bar{i}_s = [C] \begin{bmatrix} \bar{i}_s \\ \bar{\psi}_r \end{bmatrix} \dots \dots \dots (2)$$

Where  $A$  is the motor parameters matrix,  $B$  is the input matrix;  $C$  is the output matrix,  $[\bar{i}_s \ \bar{\psi}_r]^T$  is the state variables vector, and  $\bar{v}_s$  (stator voltage) is the command. The stator current and the rotor flux are estimated by the full order Luenberger state Observer described by the following equation:

$$\frac{d}{dt} \begin{bmatrix} \hat{\bar{i}}_s \\ \hat{\bar{\psi}}_r \end{bmatrix} = \hat{A} \begin{bmatrix} \hat{\bar{i}}_s \\ \hat{\bar{\psi}}_r \end{bmatrix} + B \bar{v}_s + G(\hat{\bar{i}}_s - \bar{i}_s) \dots \dots \dots (3)$$

The motor speed can be estimated by:

$$\hat{\omega}_r = K_p(\epsilon_{ids} \hat{\psi}_{qr} - \epsilon_{iqs} \hat{\psi}_{dr}) + K_i \int (\epsilon_{ids} \hat{\psi}_{qr} - \epsilon_{iqs} \hat{\psi}_{dr}) dt = \hat{\omega}_{rp} + \hat{\omega}_{ri}$$

Where  $\epsilon_{ids} = (i_{ds} - \hat{i}_{ds})$  and  $\epsilon_{iqs} = (i_{qs} - \hat{i}_{qs})$  are the current errors calculated as the difference between the measured and the estimated currents. The block diagram for Luenberger observer is represented in Figure 4.5. The basic Luenberger observer is applicable to a linear, time-invariant deterministic system.

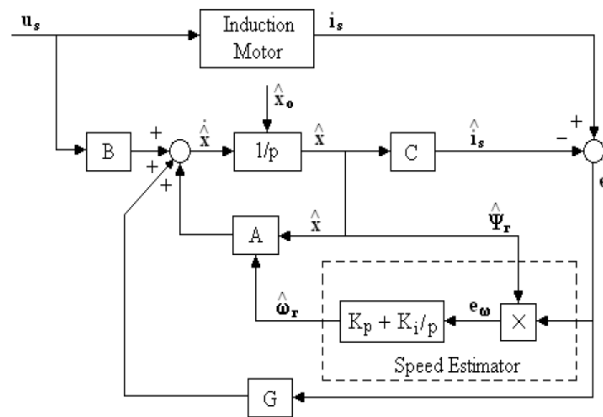

Fig 3 Luenberger based speed estimation structure.

### 6. FUZZY LOGIC:

The logic of an approximate reasoning continues to grow in importance, as it provides an inexpensive solution for controlling known complex systems. Fuzzy logic controllers are already used in appliances washing machine, refrigerator, vacuum cleaner etc. Computer subsystems (disk drive controller, power management) consumer electronics (video, camera, battery charger)



C.D. Player etc. and so on in last decade, fuzzy controllers have convert adequate attention in motion control systems. As the later possess non-linear characteristics and a precise model is most often unknown. Remote controllers are increasingly being used to control a system from a distant place due to inaccessibility of the system or for comfort reasons. In this work a fuzzy remote controllers is developed for speed control of a converter fed dc motor. The performance of the fuzzy controller is compared with conventional P-I controller.

### 6.1 Unique features of fuzzy logic

The unique features of fuzzy logic that made it a particularly good choice for many control problems are as follows, It is inherently robust since it does not require precise, noise – free inputs and can be programmed to fail safely is a feedback sensor quits or is destroyed. The output control is a smooth control function despite a wide range of input variations. Since the fuzzy logic controller processes user-defined rules governing the target control system, it can be modified and tweaked easily to improve or drastically alter system performance. New sensors can easily be incorporated into the system simply by generating appropriate governing rules.

### 3.2.3 Fuzzification and Normalization

Fuzzification is related to the vagueness and imprecision in a natural language. It is a subjective valuation, which transforms a measurement into a valuation of an objective input space to fuzzy sets in certain input universes of discourse. In fuzzy control applications, the observed data are usually crisp. Since the data manipulation in a fuzzy logic controller is based on fuzzy set theory, fuzzification is necessary in an earlier stage. The fuzzification module (FM) performs the following functions:

### 6.2 Membership functions

Generally in fuzzy system used ‘4’ different shapes of MF’s., those are Triangular, Gaussian, Trapezoidal, sigmoid, etc.,

### Triangular membership function

The simplest and most commonly used membership functions are triangular membership functions, which are Symmetrical and asymmetrical in shape Trapezoidal membership functions are also symmetrical or asymmetrical has the shape of truncated triangle

### Gaussian membership function

Two membership functions Triangular and Trapezoidal are built on the Gaussian curve and two sided composite of two different Gaussian curves.

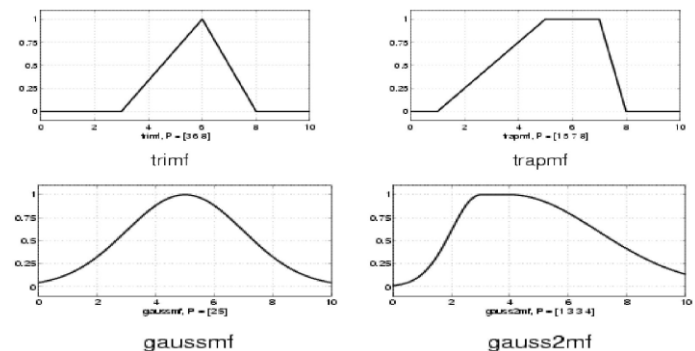

Fig 4 Membership functions

### 6.4 Fuzzy logic operators

Logical connelives are also defined for Fuzzy logic operations. They are closely related to Zadeh’s definitions of fuzzy set operation

Let denote the degree of membership of a given element x is the universe of discourse X (denoted by).

Union:  $\mu (A \cup B) = \text{MAX} [\mu A(X), \mu B(X)]$

Intersection:  $\mu (A \cap B) = \text{MIN} [\mu A(X), \mu B(X)]$

Association Property:

$$A \cup (B \cap C) = (A \cup B) \cap (A \cup C)$$

$$(A \cap B) \cup C = (A \cup C) \cap (B \cup C)$$

Distributive Property:

$$A \cup (B \cap C) = (A \cup B) \cap (A \cup C)$$

$$A \cap (B \cup C) = (A \cap B) \cup (A \cap C)$$

Absorption:

$$A \cup (A \cap B) = A$$

$$A \cap (A \cup B) = A$$

### 6.5 Fuzzy system

The fuzzy interface system Fuzzy system basically consists of a formulation of the mapping from a given input set to an output set using Fuzzy logic. The mapping process provides the basis from which the interference or conclusion can be made.

## SIMULATION RESULTS

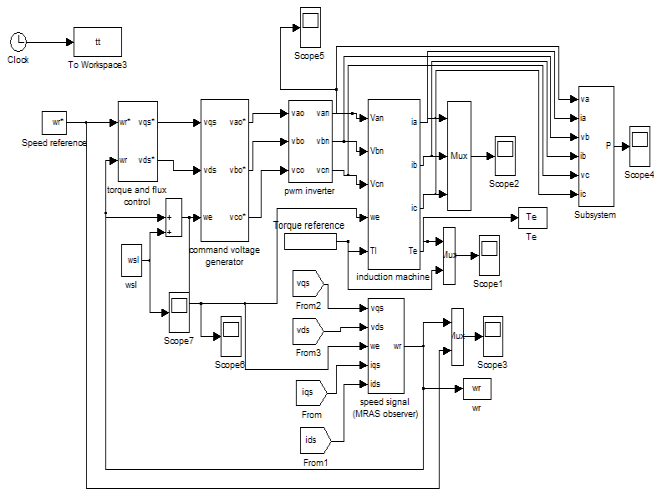

Fig 5 simulation circuit of induction motor using observer

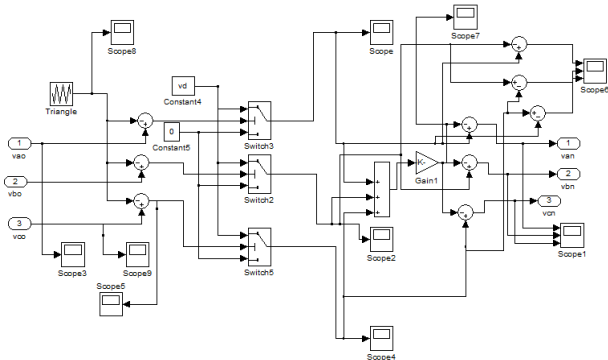

Fig 6 PWM inverter design

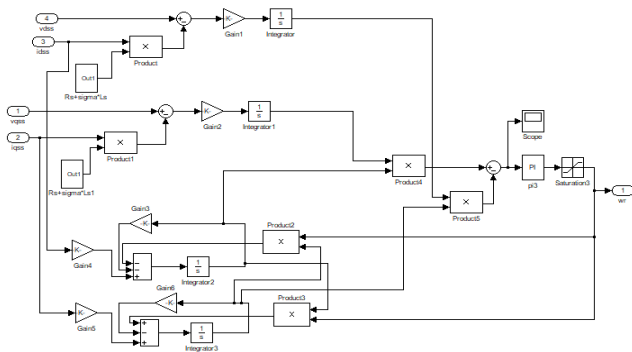

Fig 7 observer design using PI CONTROLLER

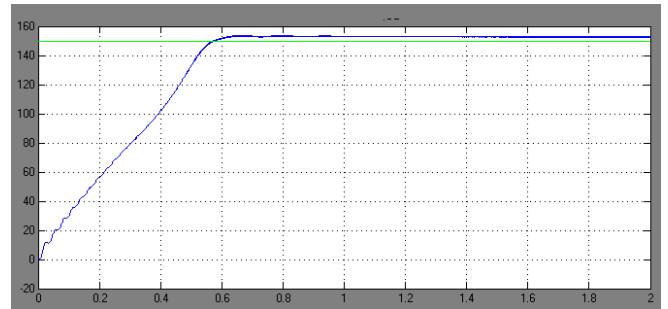

Fig 8 No load speed of 1500 rpm

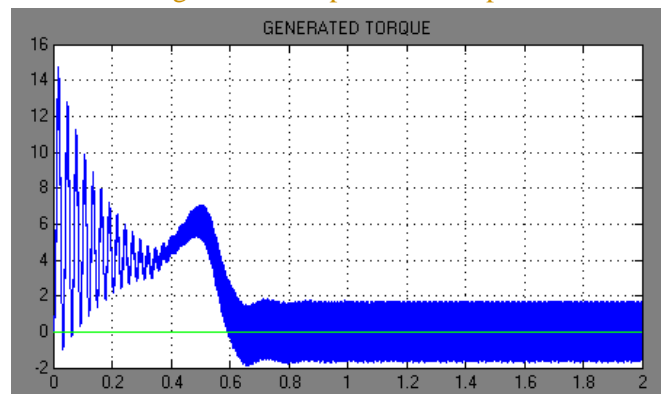

Fig 9 GENERATED TORQUE at no load

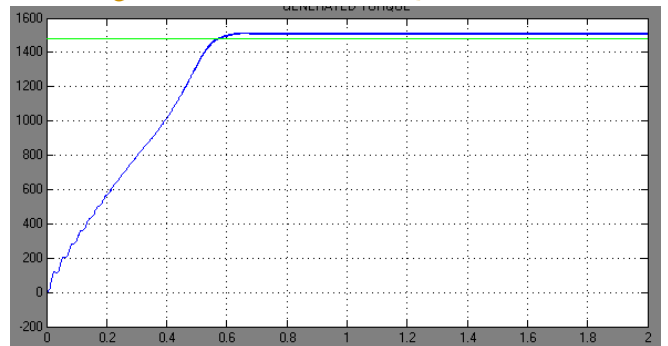

Fig 10 No load speed of 1500 rpm

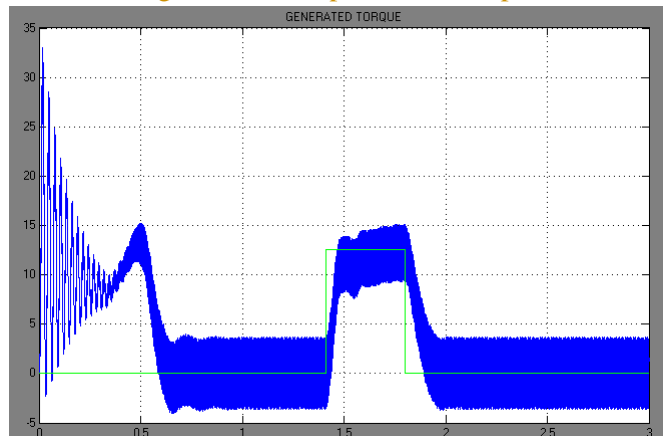

Fig 11 at load condition

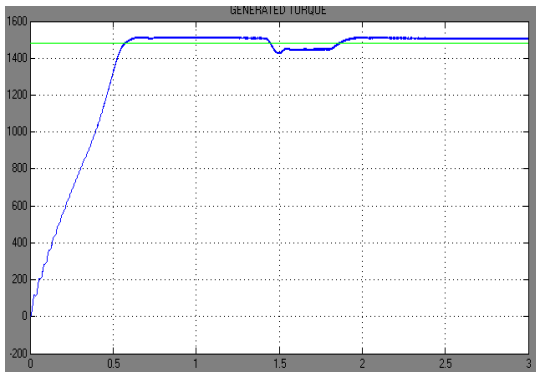

Fig 12 speed at load condition

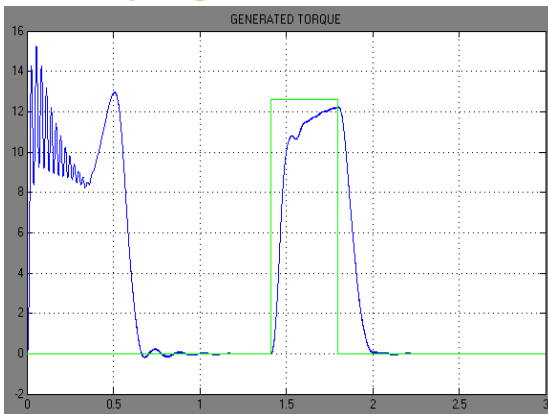

Fig 13 load torque with FUZZY control at load condition

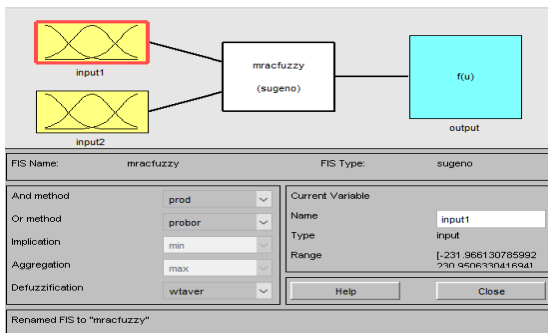

Fig 14 fuzzy fis editor

## Conclusion

In this project, Sensorless observer technique has been developed. Sensorless control gives the benefits of Vector control without using any shaft encoder. In this thesis the principle of vector control and Sensorless control of induction motor is given elaborately. The mathematical model of the drive system has been developed and results have been simulated. Simulation results of Vector Control and Sensorless Control of

induction motor using MRAS technique were carried out by using Matlab/Simulink and from the analysis of the simulation results, the transient and steady state performance of the drive have been presented and analyzed.

## REFERENCES

- [1]. Abbondanti, A. and Brennen, M.B. (1975). Variable speed induction motor drives use electronic slip calculator based on motor voltages and currents. IEEE Transactions on Industrial Applications, vol. IA-11, no. 5: pp. 483-488.
- [2]. Nabae, A. (1982). Inverter fed induction motor drive system with and instantaneous slip estimation circuit. Int. Power Electronics Conf., pp. 322-327.
- [3]. Jotten, R. and Maeder, G. (1983). Control methods for good dynamic performance induction motor drives based on current and voltages as measured quantities. IEEE Transactions on Industrial Applications, vol. IA-19, no. 3: pp. 356-363.
- [4]. Baader, U., Depenbrock, M. and Gierse, G. (1989). Direct self control of inverter-fed induction machine, a basis for speed control without speed measurement. Proc. IEEE/IAS Annual Meeting, pp. 486-492.
- [5]. Tamai, S. (1987). Speed sensorless vector control of induction motor with model reference adaptive system. Int. Industry Applications Society. pp. 189-195.